

Section A

Answer question **A1**.

A1 On the right is a sketch of a portable sign used at an airport.

(a) In the space below draw the following orthographic views:

- (i) the front view in direction of arrow **F**; [10]
- (ii) the completed end view in direction of arrow **E**; [3]
- (iii) the plan in direction of arrow **P**. [3]

Show hidden detail on all views.

Ignore how the plywood is joined to the steel tube.

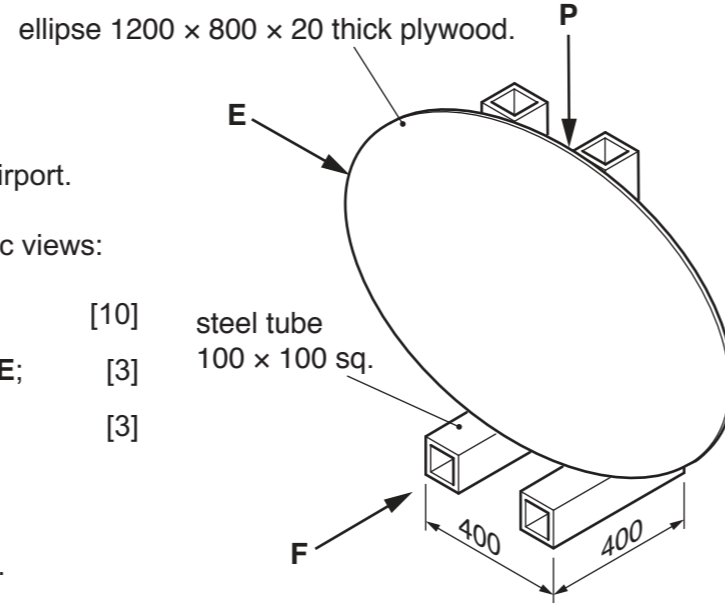

Scale 1:10

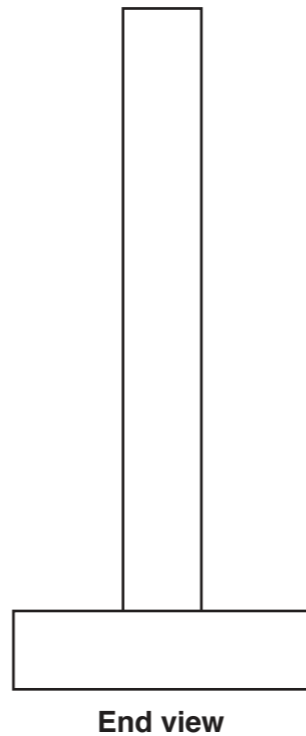
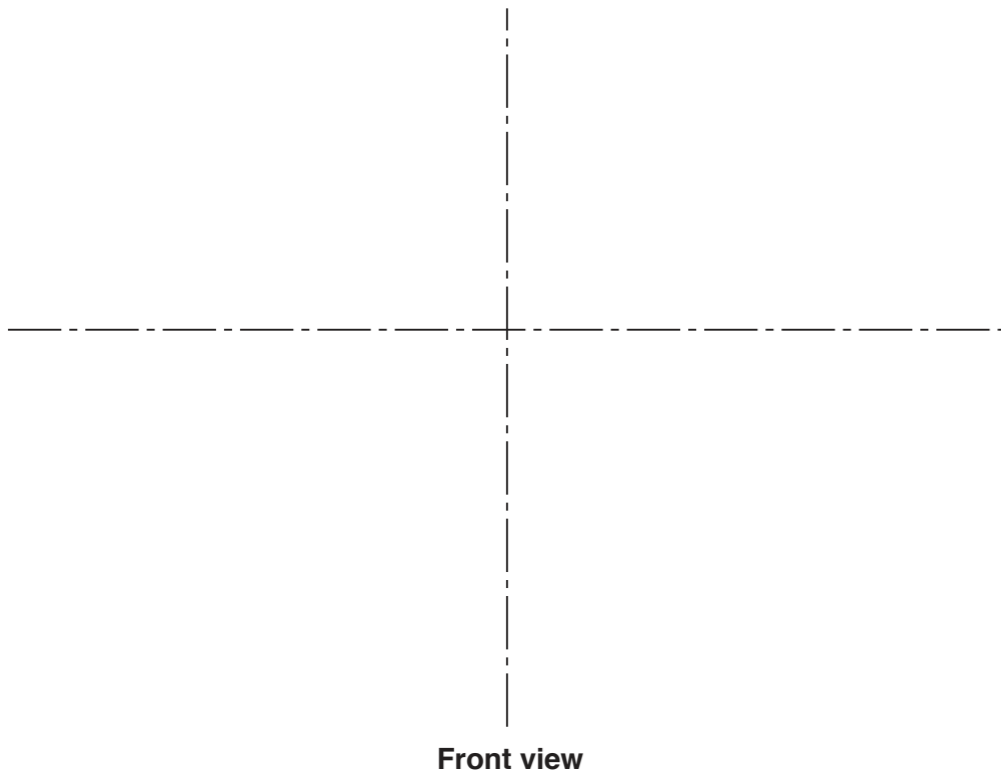

Plan

(b) Complete the symbol to show that the sign shown in part (a) is drawn in first angle orthographic projection. [3]

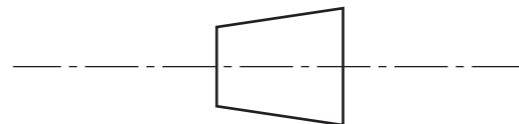

(c) The signs can be used for a number of different functions by attaching a pre-printed elliptical sheet to the plywood as shown. The pre-printed sheet is made from corrugated plastic.

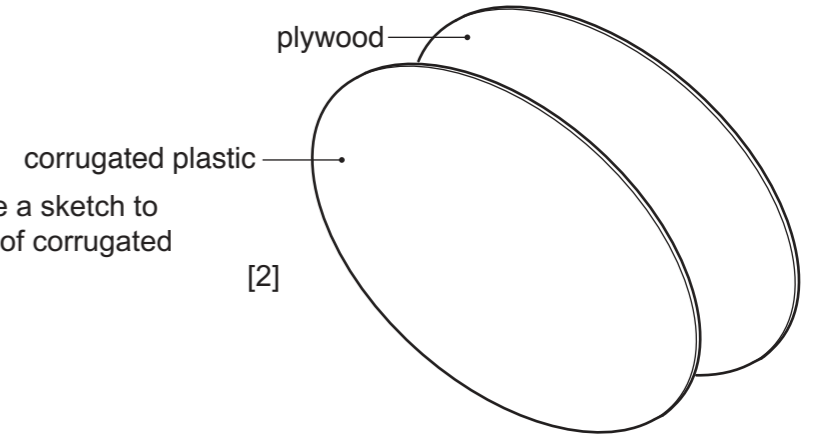

(i) In the space below use a sketch to show the construction of corrugated plastic. [2]

(ii) The text for a coffee shop sign is drawn in a font called 'Stencil'. Explain what you understand by the term font.

.....

 [2]

(iii) Complete the sign on the right by adding the word COFFEE in the same font. [3]



(iv) The corrugated plastic signs need to be changed regularly. Use notes and sketches to show how they can be changed without the need to make holes in them. [4]

For Examiner's use

7048/01 October/November 2018 **2 hours 30 minutes**
 © UCLES 2018 DC (NF/SW) 151947/3

Centre Number Candidate Number Candidate Surname Other Names **[Turn over]**

BLANK PAGE

Section B - Answer any **two** questions from this section.

B2 Geometrical shapes are used for signs at the airport.

(a) Using instruments, complete these signs by adding:

(i) concentric circles R30 and R35; [2]

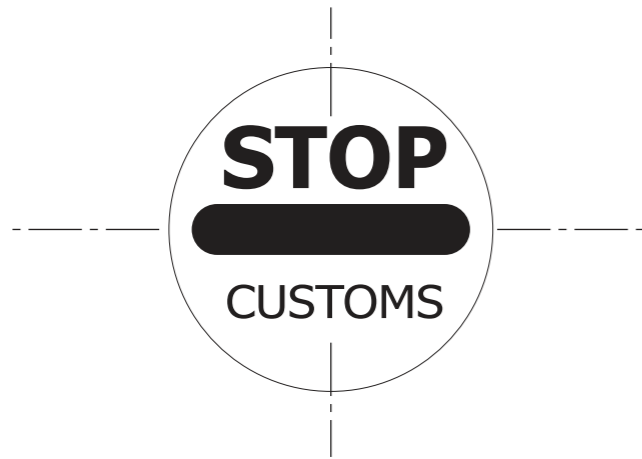

(ii) inverted equilateral triangle, length of side 60; [3]

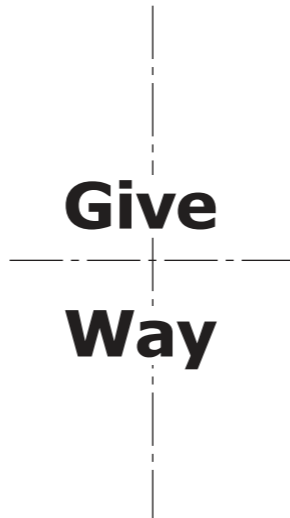

(iii) octagon, length of side 30. [3]



(b) Passengers are limited to how much baggage they can take on-board the aircraft. On the right is an orthographic drawing of baggage scales. In the space below draw an isometric view of the scales on the given isometric axes. [9]

Do not include the 25.0 kg weight in your isometric view.

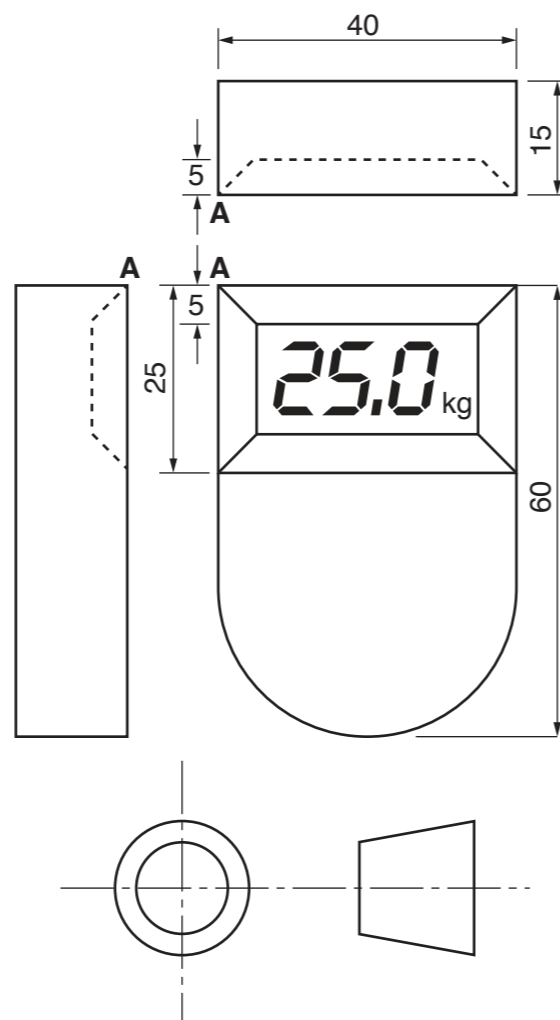
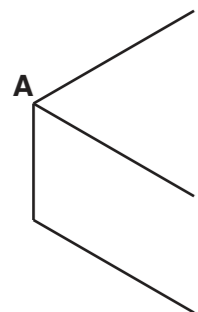

(c) Coffee is sold at the airport in plastic cups with a corrugated card sleeve.

(i) Using the drawing of the cup and sleeve shown below construct, using instruments, the development (net) of the card sleeve. [6]

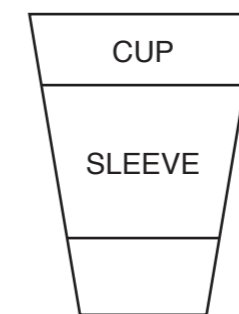

(ii) Explain why corrugated card is used for the sleeves. [2]

.....

.....

.....

.....

.....

.....

B3 (a) Rainfall for a holiday island is recorded as follows:

Season	Rainfall (mm)
Winter	200
Spring	125
Summer	75
Autumn	100

(i) Draw a three dimensional (3D) bar chart on the given axes to display the rainfall. Fully label the bar chart and use colour or shading to identify the seasons. [6]

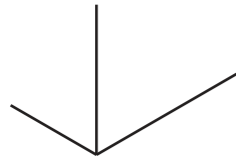

(ii) In the space below sketch a symbol to show that the bar chart refers to rainfall. [2]

(b) Sunshine for a holiday island is recorded as follows:

Season	Average hours of sunshine per day
Winter	6
Spring	9
Summer	11
Autumn	8

(i) In the space below draw a line graph to show the sunshine over the four seasons. Fully label the line graph. [5]

(ii) In the space below sketch a symbol to show that the line graph refers to sunshine. [2]

(c) A survey of passengers at the airport found that they were travelling for the following reasons:

Reason	Number of Passengers
Leisure	300
Business	240
Family	120
Other reasons	60

Using instruments, draw a pie chart to display the findings. Fully label your drawing and add colour or shading. [6]

(d) The information for the different charts is printed on to A4 paper which is sold by size and weight. A representation of a piece of A2 sized paper is shown below.

(i) On the drawing show how many pieces of A4 paper can be cut from the sheet of A2. [2]

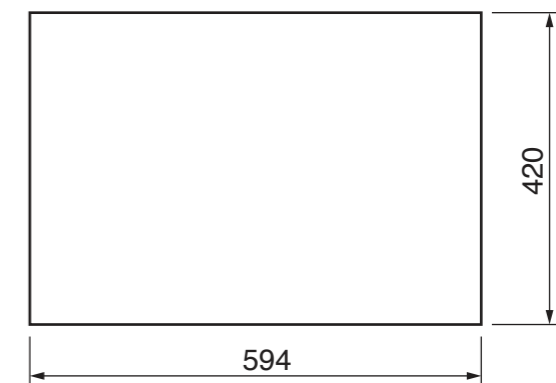

The thickness of paper is defined by its weight e.g. 100gsm.

(ii) What does 'gsm' mean?

g.....s.....m..... [2]

B4 (a) In order to help first time flyers, the airport requires a flow chart to explain the process from check-in to departure of their flight.

The stages are described below in their correct sequence.

- Arrive at the airport
- Check-in at airline desk
- Go through security
- Wait in Departure area
- Is departure gate open?
- Go to departure gate
- Board aeroplane

Complete the flow chart below.

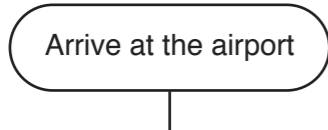

[9]

The time at your local airport is 14:00. At your destination, London, it is 11:00.

(b) In the space draw **two** symbols that show the local time and the time in London.

[5]

Symbols are used throughout airports to convey information.

(c) (i) Modify the sign to indicate that trolleys are **not** allowed. [1]

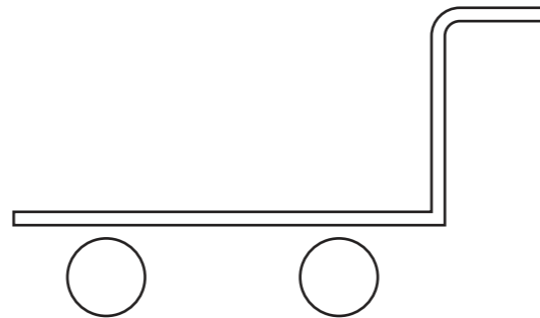

(iii) In the space below draw a symbol to show aircraft 'arrivals'. [4]

(ii) Modify the sign to indicate that 'baggage reclaim' is on the right. [2]

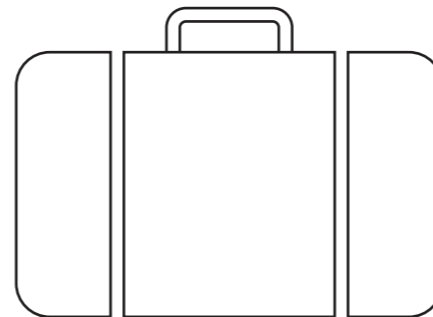

(iv) In the space below draw a symbol to show 'up escalator'. [4]

7048/01 October/November 2018 **2 hours 30 minutes**
© UCLES 2018 DC (NF/SW) 151947/3

Centre Number Candidate Number Candidate Surname Other Names

For
Examiner's
use

BLANK PAGE